

LT-3600RC LED Controller V3.00

USER INSTRUCTIONS



Pls kindly read through instructions before use

Forward

Thanks for choosing our LT-3600RC Controller. Before installation and use, we strongly recommend you to read through this manual carefully. If device has been damaged during transport, please report it to your supplier immediately. Please don't take any action without contacting your supplier first.

After-sales Service

From the day you purchase our products within a year, if being used properly in accordance with the instruction, and quality problems occur, we provide free repair or replacement services except the following cases:

1. Any defects caused by wrong operations..
2. Any damages caused by unauthorized removal, maintenance, modifying circuit, incorrect connections and replacing chips.
3. Any damages due to transportation, vibration etc after the purchase.
4. Any damages caused by earthquake, fire, lightning strike, pollution and abnormal voltage.
5. Any damages caused by negligence, inappropriate storing at high temperature and humidity environment or near harmful chemicals.
6. Product has been updated

Safety Warnings

1. Please don't install this controller in lightening, intense magnetic and high-voltage fields.
2. To reduce the risk of component damage and fire caused by short circuit, make sure correct connection
3. Always be sure to mount this unit in an area that will allow proper ventilation to ensure a fitting temperature.
4. Check if the voltage and power adapter suit the controller & if anode or cathode definition is the same as the controller's.
5. Don't connect cables with power on, make sure a correct connection and no short circuit checked with instrument before power on.
6. Please don't attempt any repairs yourself; doing so will void your manufactures warranty.

For update information, kindly please consult with your supplier.

Product Brief

LT-3600RC multi function LED controller is a universal RGB controller with high-performance, adopted the most advanced PWM control technology. It's dedicated to control entire RGB color changes of LED lights with 4 wires (common anode), such as RGB LED module, LED strip, LED tape, LED wall washer, floodlight, LED under water lamp and other LED lights.

V 3.0 is the latest & wonderful version integrated ideas from many clients; it has much more functions than V2.0, more perfect in performance, especially the soft changes in color fades, very perfect & unimpeachable, deserved to be the best RGB controller with best color smooth changes among similar products.

I . Technical Specs

Part No: LT-3600RC			
Input Voltage:	DC5V-DC24V	Speed:	8 levels
Output current:	6A/CH×3	BRT Adjust:	8 levels
Total output Power:	1 ~ 90W(5V); 1 ~ 220W(12V); 1 ~ 450W(24V)	Working Temp:	-35℃ – 55℃
		Cover Size:	L211×W40×H30(mm)
Changing Mode:	17 modes	Package Size:	L215×W43×H33(mm)
Color Depth:	Max. 256 levels per RGB	Gross Weight:	210g
Remote Distance:	50m		

II . Features

1. Controlled both by manual buttons and its fitting remote controller, reliable control distance can reach as far as 50m.
2. Automatic switch from DC5-DC24V.
3. Can turn on or off controller by ON/OFF button.

4. 3-Channel RGB full color control, maximum outputs 6A per Channel.
5. 17 modes of color skipping, color gradual changes, with color depth maximum 256 levels per RGB.
6. Speed and brightness of each mode is adjustable separately from 1-8 levels.
7. Can rest at current color and color depth by selecting PAUSE function.
8. Can restore to default settings with the newly added RESET button.
9. Used as a standalone controller or to work together with LT-3060, realizing infinite power expansion to connect any quantity of LED lights.

III. Product Dimension

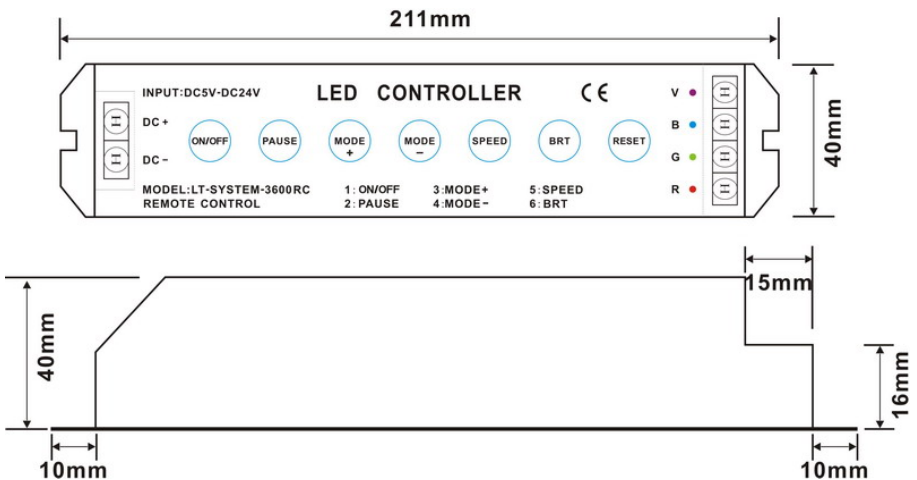

IV. Tables of changing modes

Sequence	Modes	Description
1	Static red	Supports Brightness adjustment
2	Static green	Supports Brightness adjustment
3	Static blue	Supports Brightness adjustment
4	Static yellow	Supports Brightness adjustment

5	Static purple	Supports Brightness adjustment
6	Static cyan	Supports Brightness adjustment
7	Static white	Supports Brightness adjustment
8	3 color skipping	Red, green and blue 3-color skipping
9	7 color skipping	Red, green, blue, yellow, purple, cyan, white 7-color shipping
10	White color strobe	White (with all red, green and blue on) strobe
11	3 color smooth	Red, green and blue 3-color gradual changes
12	Full color smooth	All 7-color gradual changes
13	RG color smooth	Red, green 2-color gradual changes
14	R B color smooth	Red, blue 2-color gradual changes
15	GB color smooth	Green, blue 2-color gradual changes
16	White color fade & change	white (with red, green & blue on) gradual bright & fade
17	Great cycle	All changing modes overlap cycle

V, Operating instructions

The controller, there are 7 function keys:





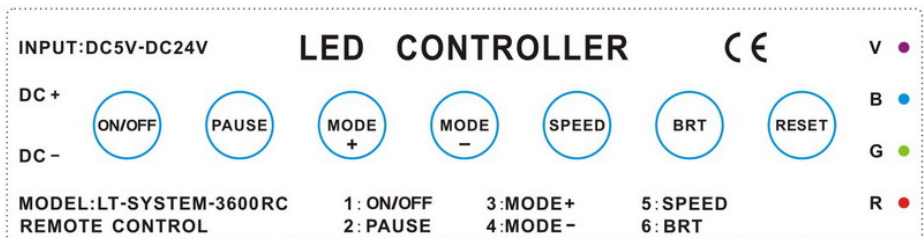



ON/OFF、PAUSE、MODE+、MODE-、SPEED、BRT、RESET

the first 6 buttons corresponding to Buton1,2,3,4,5,6 in the remote controller.





ON/OFF、PAUSE、MODE+、MODE-、SPEED、BRT、RESET

Sign	Button	RC	Description
	ON/OFF		ON/OFF: Turn on/off the controller  Any button can start the controller at off status
	PAUSE	2	Pause: Press this button will rest at current color, press it again, will continue to change.
	MODE+	3	Mode+: Press this button to select next mode
	MODE-	4	Mode-: Press this button & back to previous mode
	SPEED	5	Speed: Press this button to select 1-8 speed changing levels.
	BRT	6	Brightness: Press this button to select 1-8 brightness adjustment levels.
	RESET	1	Reset: Press it a second, enter Cycle mode; Press this button over 3 seconds, if LED flickers twice, it means it has restored to Default status successfully.

VI.Conjunction sketch map (connected to LED module as an example)

1. Connected to LED RGB module;

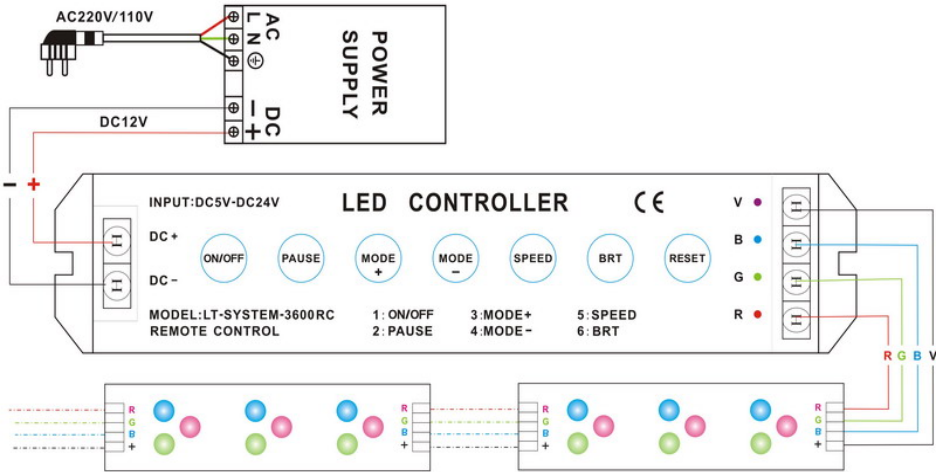

2. Connect to high power LED lights, the controller provides control signals only, the lights need extra power based on the specific working voltage of the lights, one controller can control unlimited quantity of high power LED lights.

(The high power lights must have built-in constant current driving chips)

AC100-240V

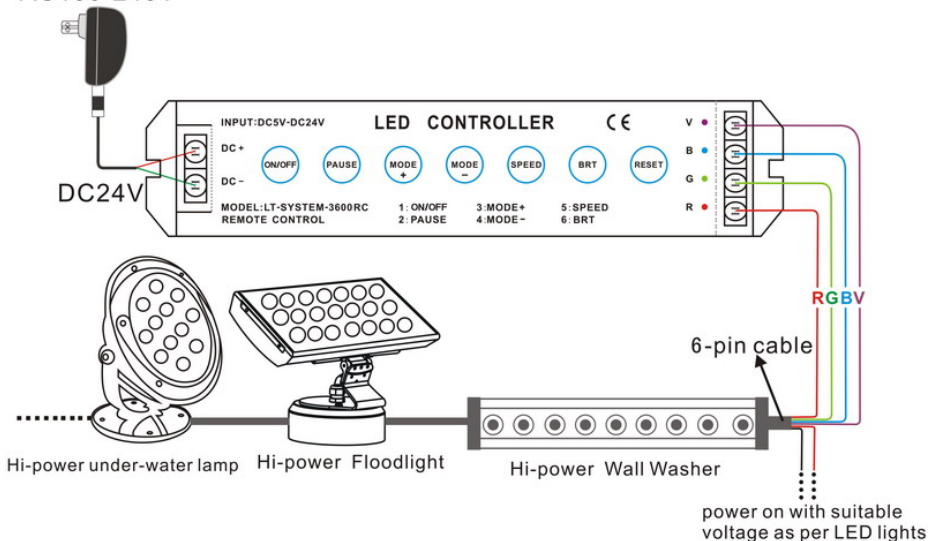

VII. Conjunction diagram, working with 3060 power amplifier(connected to LED module as an example)



3 popular conjunction methods as follows, the 3 methods can be mixed up randomly.

1. Method One: All amplifiers connected to the main power;

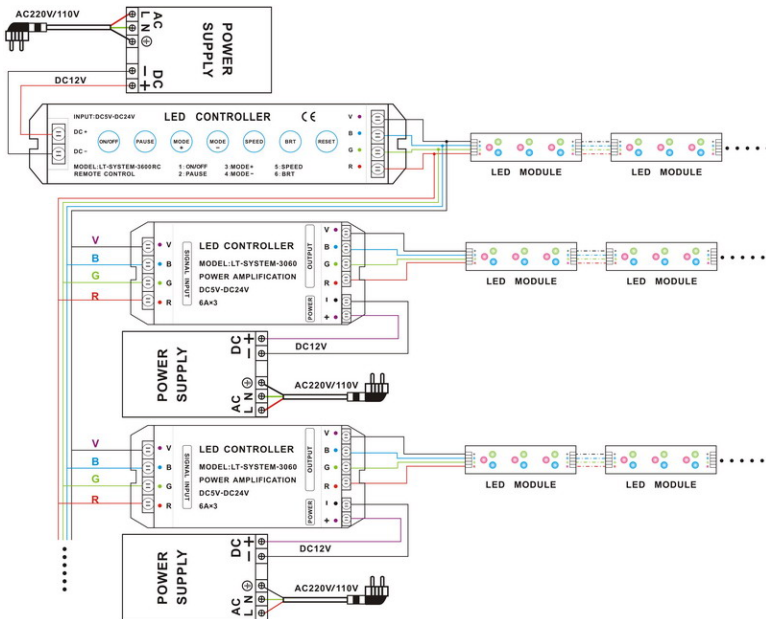

2. Method Two: Connect the controller and the amplifier by a method of “hand in hand”.

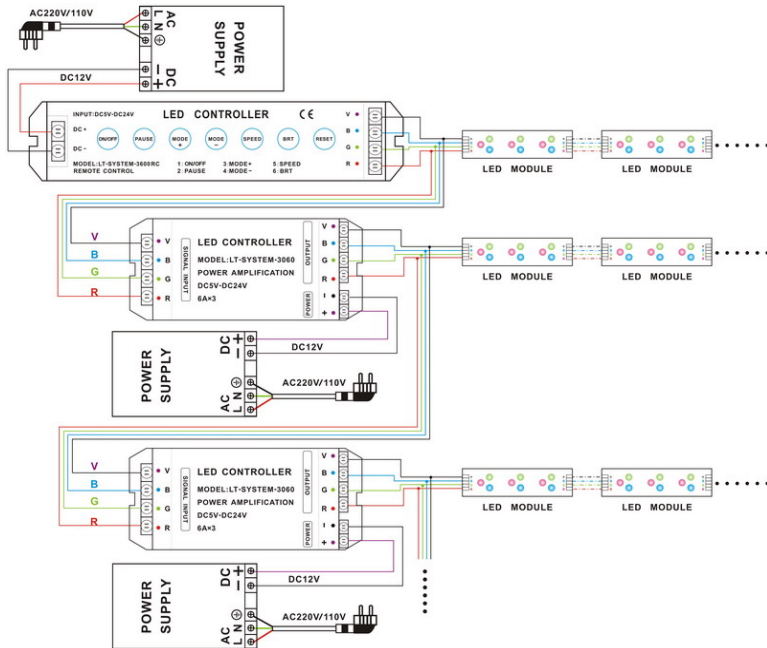

3. Method Three: The LED modules are followed by amplifiers in series.

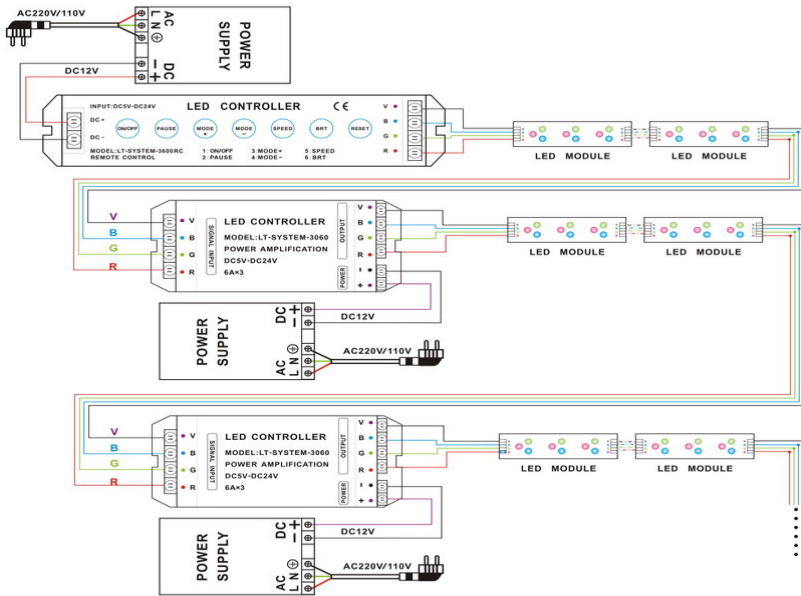

VIII. Exception Handles

Malfunction	Causation	Settle
No Light	1. No power from plug 2. Power supply protector works 3. Incorrect connection	1. Check the socket 2. Check the malfunction, re-power on 3. Check connection
Incorrect color Amplifier not in phase	4. Incorrect RGB output wire connection 5. Incorrect in-phase connection	4. Re-connect RGB wires correspondently 5. Re-connect in-phase wires correspondently
No response from button	6. Selected Pause button	6. Press Pause or Reset button again
No changes from certain mode	7. Speed is too slow	7. Press Speed to accelerate
Uneven brightness between front and rear, with voltage drop	8. Output cable is too long 9. Wire diameter is too small 10. Overload beyond controller capability	8. Reduce cable or use loop circuit. 9. Change wider wire 10. Change power supply or add power amplifier
Remote controlling unavailable	11. Battery without power 12. Out of remote-control distance	11. Change battery 12. Reduce remote-control distance